

TUBE.55/AIR

Pneumatic drilling machine

EUROBOOR

FOR PROFESSIONALS BY PROFESSIONALS

Technical data

	Metric	Imperial
Annular cutting	Ø 12 - 52 mm (HSS)	Ø 7/16" - 2 1/16" (HSS)
	Ø 12 - 55 mm (TCT)	Ø 7/16" - 2 3/16" (TCT)
Twist drilling	Ø 1 - 23 mm	Ø 1/16" - 15/16"
Countersinking	Ø 12 - 55 mm	Ø 7/16" - 2 3/16"
Length	345 mm	13 9/16"
Width	245 mm	9 5/8"
Height	630 - 730 mm	24 13/16" - 28 3/4"
Stroke	167 mm	6 9/16"
Weight*	16.7 kg	36.8 lbs
Magnet	275 x 190 x 80 mm	10 13/16" x 7 1/2" x 3 1/8"
Magnetic force	900 kg	1,984 lbs
Full saturation as from	12,5 mm	1/2"
Min. material thickness	3 mm	1/8"
Min. pipe diameter	80 mm	3 1/8"
Speed (no load)		380 rpm
Spindle (Weldon)	MT3 19.05 mm	MT3 3/4"
Power source	Air, min. 6.3 bar, max. 8 bar, consumption 1.1 m³/min	

* Without handles

Features



Air motor:
min 6.3 bar
(90 PSI)



Atex



Round outer

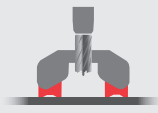

Flat surface



Round inner

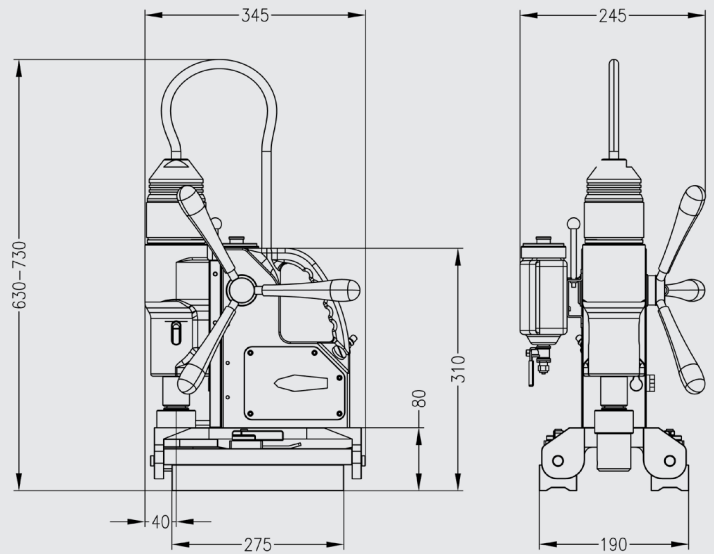

Euroboor makes every effort to meet quality and integrity requirements. That is why we as an organization are proud of the recognition of some leading organizations worldwide:



www.euroboor.com